

MagMixer MBI

SANSTAR SANITARY MIXER



A World Leader in Industrial Mixing since 1923, Lightnin has 90 years of unrivaled experience in industrial mixing technology, process knowledge, and technological innovation. Lightnin enjoys a global reputation for durable, long-lasting mixers, agitators, aerators, and flocculators for fluid process systems. We offer a full spectrum of impeller designs for diverse applications. In addition, we offer a worldwide service network, mixer repair, gearbox repair, and replacement parts programs. Look to Lightnin for knowledge, technology, and service excellence.

SPX FLOW, Inc. (NYSE:FLOW) is a leading manufacturer of innovative flow technologies, many of which help define the industry standard in the market segments they serve. From its headquarters in Charlotte, North Carolina, it operates a sales and support network, centers of manufacturing excellence, and advanced engineering facilities, throughout the world. Its cutting-edge flow components and process equipment portfolio includes a wide range of pumps, valves, heat exchangers, mixers, homogenizers, separators, filters, UHT, and drying technology that meet many application needs. Its expert engineering capability also makes it a premium supplier of customized solutions and complete, turn-key packages to meet the most exacting of installation demands. Incorporating many leading brands, SPX FLOW has a long history of serving the food and beverage, power and energy, and industrial market sectors. Its designs and engineered solutions help customers drive efficiency and productivity, increase quality and reliability, and meet the latest regulatory demands. In-depth understanding of applications and processes, state-of-the-art Innovation Centers, and advanced pilot/testing technology further assist in optimizing processes and reducing timescales to reliably meet production targets. To learn more about SPX FLOW capabilities, its latest technology innovations and complete service offerings, please visit www.spxflow.com.

A Standard for Cleanability, Durability and Performance - MagMixer MBI

The Lightnin MagMixer™ MBI sets the standard for cleanability, durability and performance in food, pharmaceutical, biotech and personal care applications. Features include a dry-running Hyper-Flo™ bearing design, one-piece tank plate and flow-through channels, totally eliminating contamination concerns. These technologically-advanced mixers are fast-becoming the critic's choice for sanitary processing and storage applications – including plasma fractions, vaccines, injectables, media suspensions, buffer prep, cell culture and beverage blending.

DESIGNED FOR DURABILITY AND SUPERIOR PERFORMANCE

- Suitable for up to 30,000 liters (7,925 gal.) and viscosities up to 1,000 cp. (Viscosity limits depend on tank volume)
- Available CE Marked.
- Comes with Lightnin's 100% process guarantee.

DESIGNED FOR EASY MAINTENANCE

- Unlike sleeve bearings, which must be sent back to the factory for replacement, Hyper-Flo bearings can be replaced on-site using only a pair of snap-ring pliers.
- Motors and drive assemblies weigh from 12-24 kgs (25-51 lbs.), depending on size, for easier handling.
- Drive can be rotated through 360° for easy maintenance access and to minimize interference with other external tank components.
- Common spare parts and same bearing design used in all four sizes of MBI.
- Easily maintained on-site, in seconds.

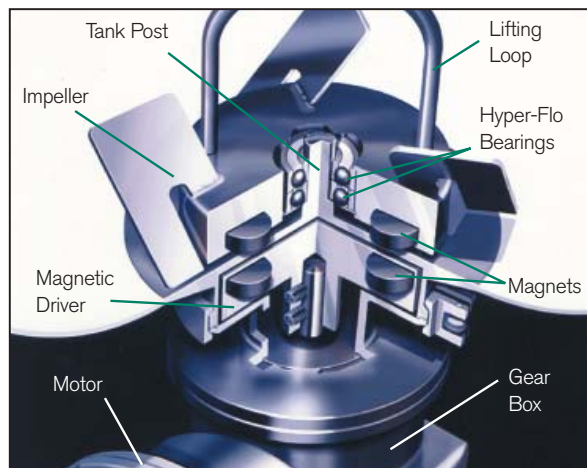

The patented Hyper-Flo bearing system is more cleanable and produces significantly less particulates than conventional sleeve bearing designs.

MBI 410-610-810

MAGMIXER MBI 205

The Lightnin MagMixer MBI 205 is an extension of the MagMixer MBI family. This small footprint design further establishes the series for its benchmark cleanability, durability and performance in pharmaceutical and biotechnology applications. This exceptionally versatile mixer is suitable for solutions in open and closed tanks from 20 liters (5 gal.)



MBI 205



MBI 410-610-810



"Crush-Proof" Bearings! Steel dimpled after applying 10,000 psi to bearing.

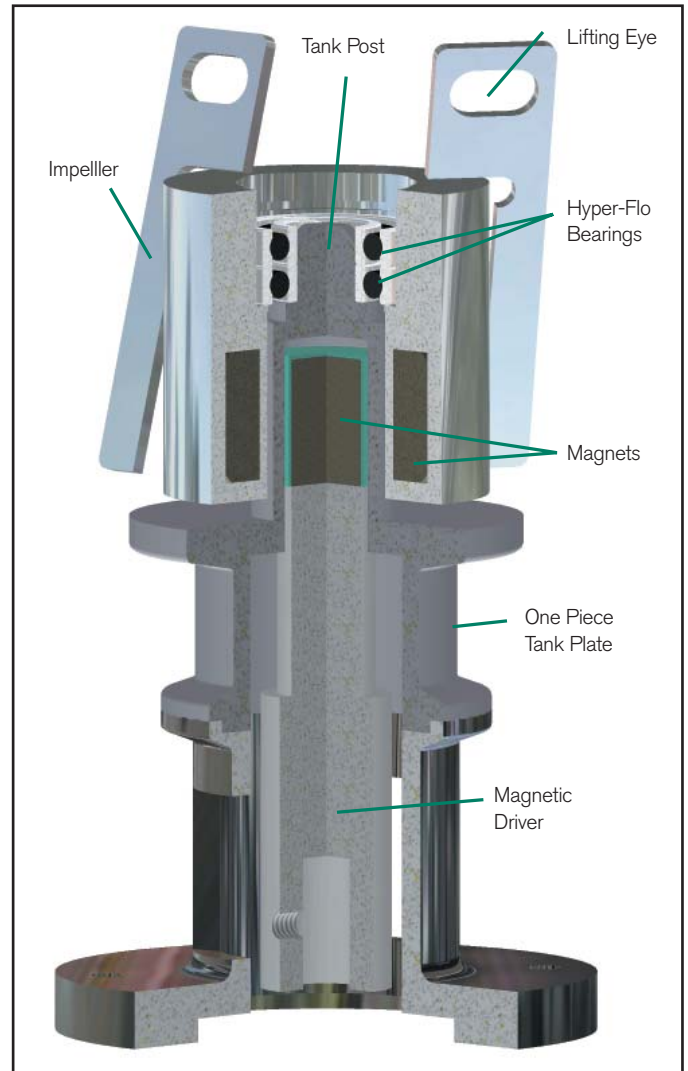

The MBI 205 provides the same process performance, ability to run dry, and process cleanability for small tank applications.

CLEANING TO A GREATER DEGREE...

The cleanability of Lightnin's MagMixer MBI impeller is proven - validated both in factory acceptance tests and in actual process performance in hundreds of installations.

Designed for Maximum Cleanability

- The patented Hyper-Flo™ bearing design has been proven more cleanable than sleeve bearing designs. Independent tests comparing the newer MagMixer MBI to an older design and the leading competitive product concluded that the MagMixer MBI is easier to clean, especially in applications involving sticky, hard-to-clean soils.

- Can be Cleaned in Place (CIP) using spray-only or immersion protocols.
- Can be run dry to permit complete draining during CIP cycles.
- Impeller assembly can be autoclaved –magnets designed to withstand temperatures up to 300° F.
- Bearings can be removed easily for Cleaning Out of Place (COP) or maintenance.
- The Hyper-Flo bearings are constructed of wether Zirconium Oxide, Silicon Nitrite, or MP35N for corrosion resistance, strength and bio-compatibility.

MagMixer MBI

SANSTAR SANITARY MIXER



For other Sales locations click www.lightninmixers.com/contacts/where-to-buy/ or use your SmartPhone and the QR Code

SPXFLOW

SPECIFICATIONS

Impeller

- 3 bladed 316L Stainless Steel
- Hyper-Flo™ bearing design
- 20 μ-inch Ra finish with EP standard (optional 10 μ-inch Ra finish with EP)

Tank Plate

- 316L SS one-piece tank plate
- Certificate of Compliance and Mill Certificate shipped with each tank plate
- Surface finish per customer specification (32 μ-inch Ra minimum)

Drive Assembly

- .25 - .75 kW (1/3 - 1 HP)
- Lightweight aluminum alloy IP56 reducer with integral motor
- Washdown duty drive, with FDA approved lubricant 1.25 AGMA SF
- Severe-duty washdown motor
- 316SS pedestal with Tri-Clamp fitting
- Optional: 300-Series stainless steel drive available

Motor Options

- IP55 (washdown), 56C TEFC, Single-phase, 115V, 50 or 60 Hz, DC
- AC washdown duty, TENV stainless motor with inverter
- All stainless steel motor
- XP C&D inverter duty motor
- NEMA 4/12 SCR controller

Custom Options

- High alloy, non-ferrous tank plate and impeller
- Tank plates for jacketed vessels
- Tachometer
- White epoxy or stainless steel paint

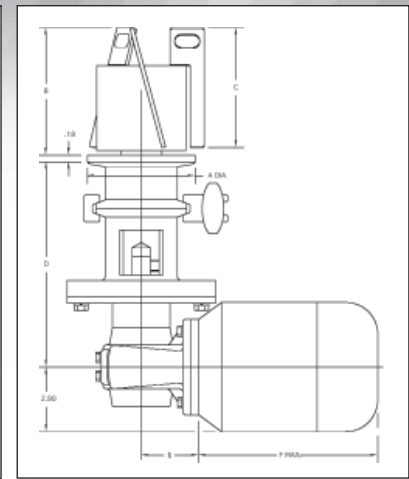
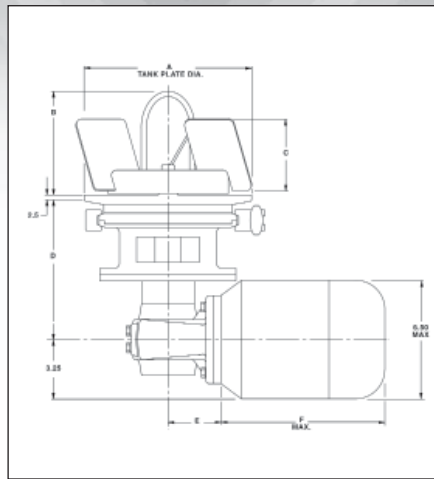

MagMixer MBI 205 (Dim. in inches)

Model	HP	A	B	C	D	E	F	F	Impeller Dia.	Tank Plate Dia.
MBI 205	.33	3	3.5	3.3	6.3	2.4	8.4	13	3.5	3

5:1 ratio (nominal 350 rpm)

MagMixer MBI 410, 610, 810 (Dim. in inches)

Model	HP	A	B	C	D	E	F	F	Impeller Dia.	Tank Plate Dia.
MBI 410	.50	6	5	2.5	6.5	2.4	8.4	13	6.25	6
MBI 610	.75	8	5.1	3.4	6.5	2.4	9.1	15	8.75	8
MBI 810	1.0	11.75	5.2	3.9	7.2	2.4	9.1	16.5	11.25	11.75

10:1 ratio (nominal 175 rpm)



SPX FLOW, LLC - LIGHTNIN & PLENTY MIXERS

135 Mt. Read Blvd., Rochester, NY 14611

P: (888) 649-2378 (MIX-BEST), (US and Canada) or +1 (585) 436-5550

E: lightnin@spxflow.com • www.spxflow.com/lightnin

SPX FLOW, Inc. reserves the right to incorporate our latest design and material changes without notice or obligation. Design features, materials of construction and dimensional data, as described in this bulletin, are provided for your information only and should not be relied upon unless confirmed in writing. Please contact your local sales representative for product availability in your region. For more information visit www.spxflow.com. The green ">" is a trademark of SPX FLOW, Inc. ISSUED 12/2015 B-953 COPYRIGHT © 2015 SPX FLOW, Inc.